

**Digital Color  
Progressive Scan Camera**

 System: **Gigabit Ethernet**
**Baumer TXG20c-I7**

Revision 2

**Art. No: OD108713**

- Gigabit Ethernet progressive scan CCD camera
- 1624 x 1232 pixel
- Up to 16 full frames per second
- GigE Vision<sup>®</sup> standard compliant
- On board integrated color processor for high quality color calculation
- Outstanding image quality
- High sensitivity and dynamic range
- High quality slow scan mode for lowest readout noise
- True partial scan function (ROI) for increased frame rates
- External synchronization via industrial compliant process interface (trigger / flash)
- Integrated supplementary function for flexible integration
- Jumbo frames supported
- Integrated 32 MByte RAM for temporarily image data buffering
- Camera parameter programmable in real-time
- Ultra compact and lightweight aluminum housing
- IP67 camera housing design based on EHEDG recommendation
- Standard M12 industrial connector
- Baumer-GAPI: Flexible, generic software interface for Windows / Linux



shown lens and tubes need to be ordered separately

**1. Overview**

Model Name	TXG20c
Sensor	1/1.8" interline progressive scan CCD
Shutter / readout mode	global shutter / progressive scan readout
Number of pixel	1624 x 1232
Scan area	7.15 mm x 5.42 mm
Pixel size	4.4 µm x 4.4 µm
Color filter	RGB Bayer mosaic
<b>Operation modes</b>	
Trigger mode	yes, overlapped operation
Free running mode	yes, overlapped operation
<b>Signal processing</b>	real-time software programmable
Pixel clock	40 MHz fast scan / 20 MHz high quality (HQ) scan
A/D converter	12 bit
Exposure control ( $t_{exp}$ )	total: 4 µsec .. 60 sec step: 1 µsec
Gain control	0 .. 20 dB
Offset (black level)	0 .. 255 LSB (12 bit)
Image data buffer	max. 3 images

Technical specifications subject to change

Image acquisition							
Camera image format modes	Format (pixel)	GenCam standard	Format ID	Pixel format	Pixel clock MHz	Frames per sec. *)	t <sub>readout</sub>
Full frame HQ slow	1624 x 1232	Vendor specific	00	BayerRG8	20	8	125 msec
				BayerRG12			
				Mono8			
				YUV411 Packed			
				YUV422 Packed **)			
				YUV444 Packed			
				RGB8 Packed			
Full frame fast	1624 x 1232	yes	01	BayerRG8	40	16	63 msec
				BayerRG12			
				Mono8			
				YUV411 Packed			
				YUV422 Packed **)			
				YUV444 Packed			
				RGB8 Packed			
BGR8 Packed							
<b>Standard features</b>							
<b>Image size controls</b>							
Pixel format	BayerRG8, BayerRG12, Mono8, YUV411 Packed, YUV422 Packed, YUV444 Packed, RGB8 Packed, BGR8 Packed						
Test image selector	yes, in all modes Off, GreyHorizontalRamp, GreyVerticalRamp, HorizontalLineMoving, VerticalLineMoving, HorizontalAndVerticalLineMoving						
Partial scan	yes, format freely programmable in all modes						
<b>Analog controls</b>							
Gain	yes						
Black Level (Off set)	yes						
Gamma	no						
<b>Acquisition and Trigger</b>							
Acquisition mode	Continuous						
Trigger source	HardwareTrigger (Line0), SoftwareTrigger, CommandTrigger (ActionCommand), All or Off						
Trigger delay	0 .. 2 sec, 512 trigger can be tracked, step: 1 µsec						
Sequencer	no						
<b>Digital I/O</b>							
Lines	Line0 (Input), Line1 (Output)						
Line source (outputs only)	Line1: Off, ExposureActive or UserOutput						
Line debouncer	yes, low and high signal separately selectable 0 .. 5 msec step: 1µsec						
<b>Event Generation</b>							
Events	GigEVisionError, EventLost, Line0RisingEdge, Line0FallingEdge, Line1RisingEdge, Line1FallingEdge, ExposureStart, ExposureEnd, FrameStart, FrameEnd, TriggerReady, TriggerOverlapped, TriggerSkipped						
Event Notification	yes, ON / OFF						
<b>Counters and Timers</b>							
Framecounter	yes, 2 <sup>32</sup> can be set by user						
<b>LUT Controls</b>							
LUT selector	no						
Defect pixel correction (custom)	yes, ON / OFF						
Defect pixel list (custom)	yes, max. 256 pixel coordinates (x, y) can be stored						
<b>GigEVisionTransportLayer</b>							
PayLoadsize	4 Byte .. 6.002.576 Byte						
<b>UserSets</b>							
User set selector	Default (factory settings / read only) UserSet1, UserSet2, UserSet3 (read and write)						
UserSetDefaultSelector	yes, define the start up "UserSet"						



<b>Housing</b>	aluminum, IP67			
Dimensions	Ø 65 mm x 50 mm			
Weight camera	< 360 g			
Weight tube	52 mm	62 mm	71 mm	94 mm
	< 120 g	< 140 g	< 150 g	< 200 g
<b>1000 Base-T interface</b>	1000 Mbit / sec			
Ethernet IP configuration	persistent IP / DHCP / LLA			
Stream channel packet size	576 Byte (default) .. 65535 Byte jumbo frames supported			
Interpacketgap	0 .. 2 <sup>32</sup> -1 ticks			
Resend function	yes			
<b>Software</b>	Baumer-GAPI SDK with supported OS socket driver and Baumer filter driver / SDK for Windows XP (32 bit) / Windows Vista (32 bit / 64bit) Linux Kernel 2.6.xx (64 bit / 32 bit)			
	GigE Vision® compatible programs and image processing libraries supported Windows / Linux depending on the actually driver software is used			

- \*) maximum frame rate in free running mode, effective frame rate depending on camera image format mode settings and set exposure time ( $t_{exp} < t_{readout}$ )
- \*\*) default pixel format
- \*\*\*) can be inverted via software
- \*\*\*\*) housing temperature is limited by CCD sensor specification

## 2. Camera Factory Settings after Camera Start-up

	Camera factory settings after camera start-up
<b>Operation modes</b>	free running mode
<b>Signal processing</b>	
Exposure control	32 msec
Gain control	factor 1 = 0 dB
Offset (black level)	0
<b>Image acquisition</b>	
Camera image format mode	mode id = 01, full frame YUV422 Packed
Partial scan function	not active
Test image selector	Off
Defect pixel correction	On
<b>Electrical interface</b>	
Exposure Active (External flash sync)	disabled, digital output set to low status (high impedance) invert = false line source = Exposure Active
Async. Trigger	disabled invert = false trigger source = Line0

### 3. Timing Operation Modes

Trigger Mode: start up time

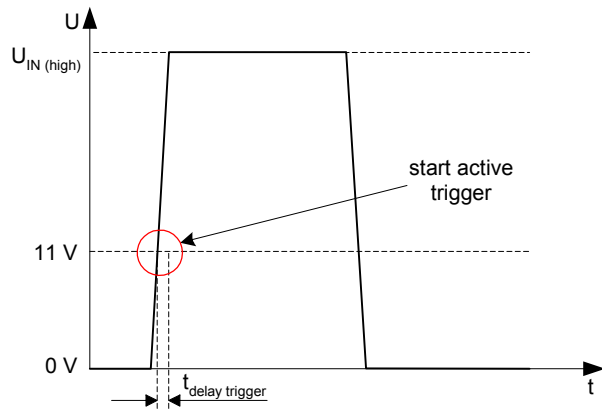

Trigger Mode: trigger mode 0, overlapped trigger

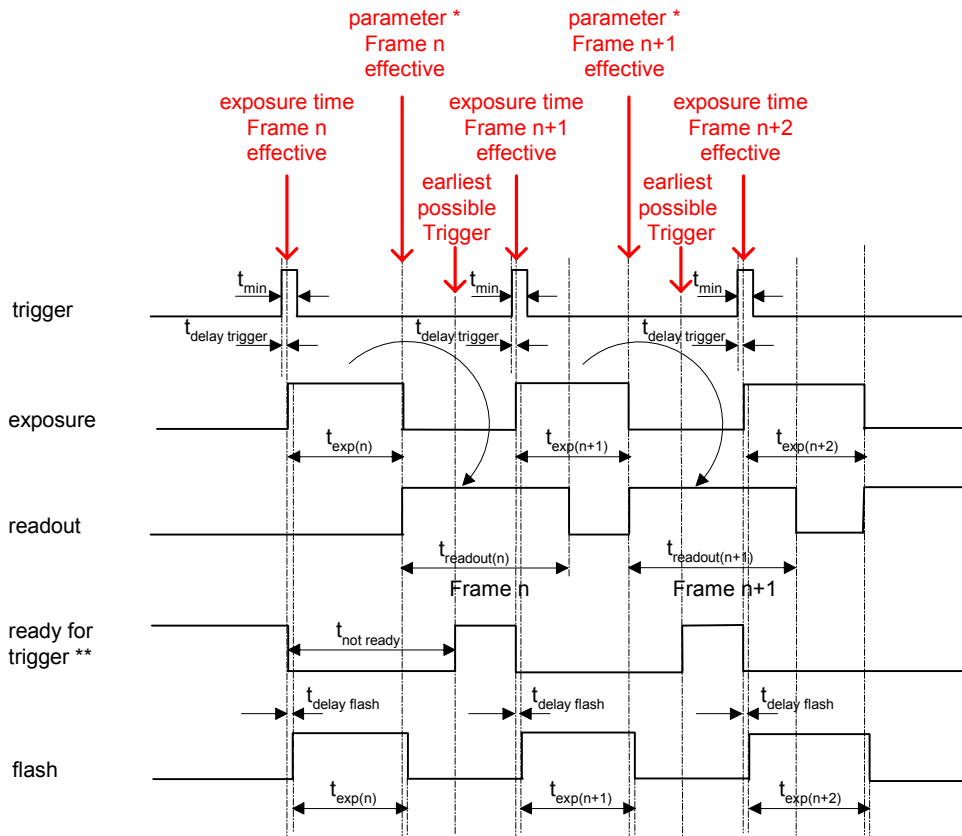

$$t_{exp} < t_{readout}: t_{earliest\ possible\ trigger\ (n+1)} = t_{readout(n)} - t_{exp(n+1)}$$

$$t_{exp} > t_{readout}: t_{earliest\ possible\ trigger\ (n+1)} = t_{exp(n)}$$

$$t_{exp} < t_{readout}: t_{not\ ready\ (n+1)} = t_{exp(n)} + t_{readout(n)} - t_{exp(n+1)}$$

$$t_{exp} > t_{readout}: t_{not\ ready\ (n+1)} = t_{exp(n)}$$

\* image parameter: offset  
global gain  
mode  
partial scan

\*\* signal will be notified as event "TriggerReady" and is not available as digital output

Trigger Mode: trigger mode 0, overlapped trigger , when  $t_{exp(n+2)} > t_{exp(n+1)}$

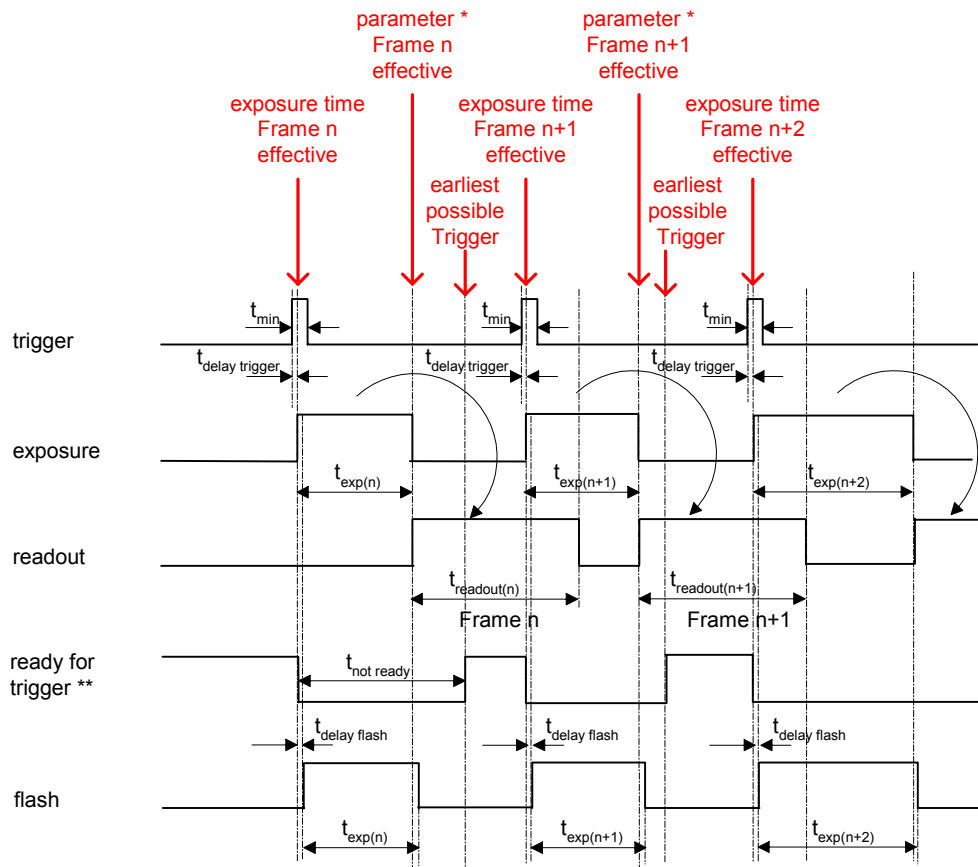

$$t_{exp} < t_{readout}: t_{earliest\ possible\ trigger\ (n+1)} = t_{readout(n)} - t_{exp(n+1)}$$

$$t_{exp} > t_{readout}: t_{earliest\ possible\ trigger\ (n+1)} = t_{exp(n)}$$

$$t_{exp} < t_{readout}: t_{not\ ready\ (n+1)} = t_{exp(n)} + t_{readout(n)} - t_{exp(n+1)}$$

$$t_{exp} > t_{readout}: t_{not\ ready\ (n+1)} = t_{exp(n)}$$

\* image parameter:    offset  
                               global gain  
                               mode  
                               partial scan

\*\* signal will be notified as event "TriggerReady" and is not available as digital output

Trigger Mode: trigger mode 0, overlapped trigger , when  $t_{exp(n+2)} < t_{exp(n+1)}$

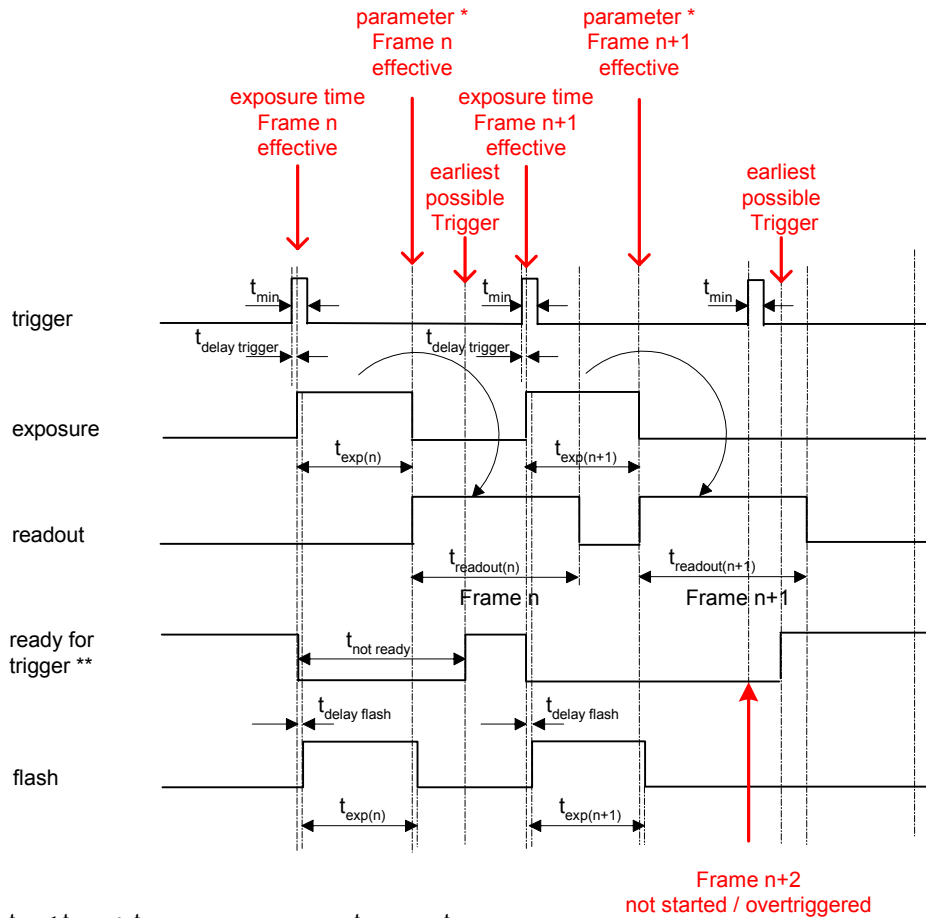

$$t_{exp} < t_{readout} : t_{earliest\ possible\ trigger\ (n+1)} = t_{readout(n)} - t_{exp(n+1)}$$

$$t_{exp} > t_{readout} : t_{earliest\ possible\ trigger\ (n+1)} = t_{exp(n)}$$

$$t_{exp} < t_{readout} : t_{not\ ready\ (n+1)} = t_{exp(n)} + t_{readout(n)} - t_{exp(n+1)}$$

$$t_{exp} > t_{readout} : t_{not\ ready\ (n+1)} = t_{exp(n)}$$

\* image parameter: offset  
global gain  
mode  
partial scan

\*\* signal will be notified as event "TriggerReady" and is not available as digital output



Free Running Mode: overlapped operation

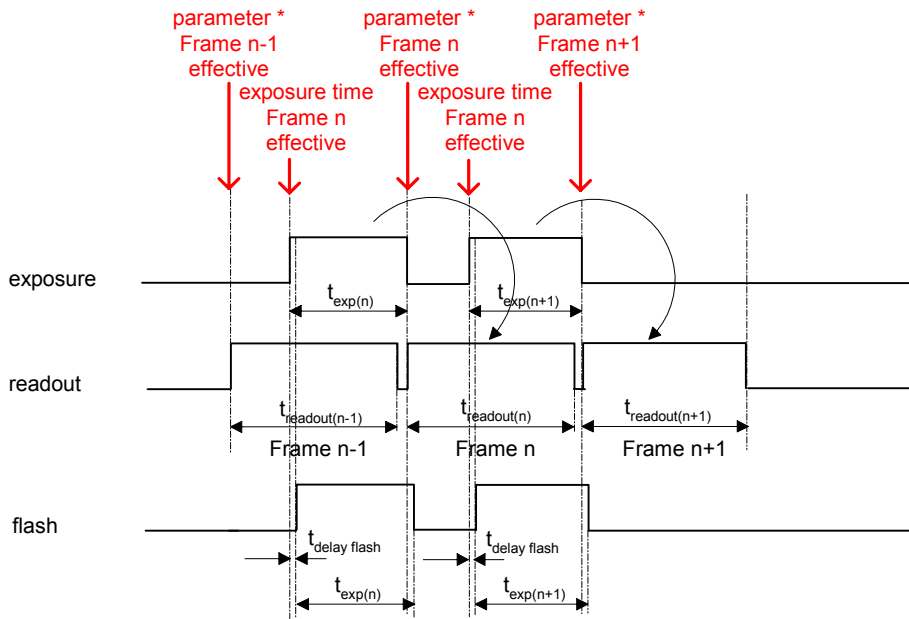

\* image parameter: offset  
 global gain  
 mode  
 partial scan

## 4. Housing

### 4.1 Camera

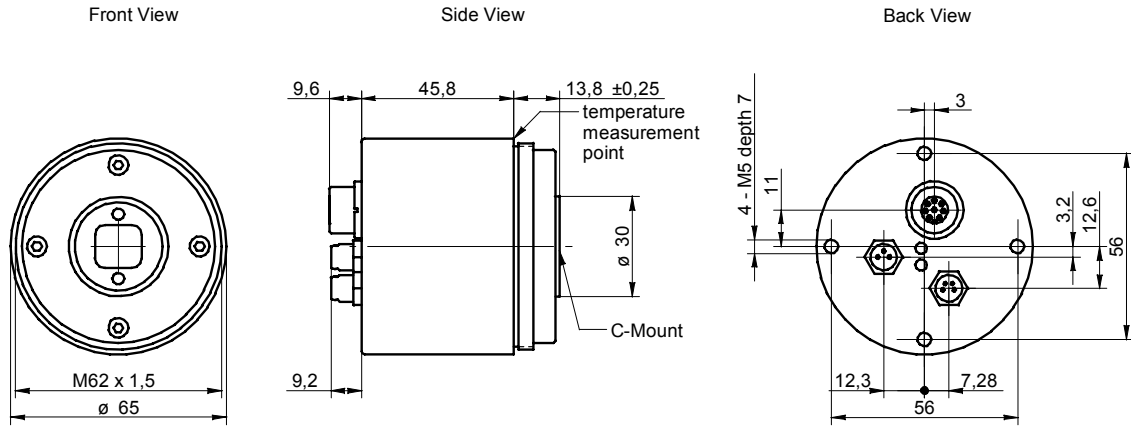

4.2 Tube

Front View

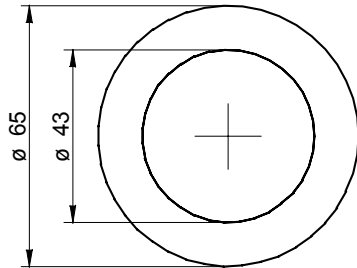

Side View

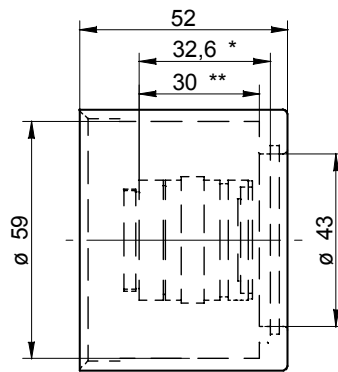

Item Number

OD108571

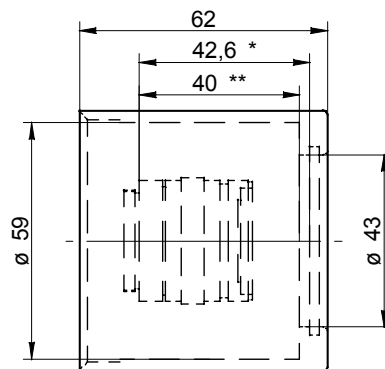

OD108568

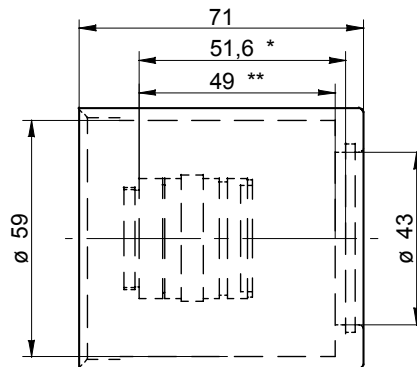

OD108569

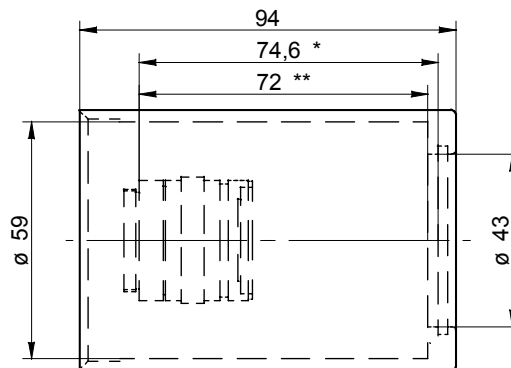

OD108570

\* max. installation space between C-mount and glass

\*\* max. installation space between C-mount and cylinder bottom

5. Connectors / Electrical Interfaces

5.1 Pin assignment:

Data / Control 1000 Base-T	Type: female M12 / 8 pin A cod.
	1: MX3- 2: MX4+ 3: MX4- 4: MX1- 5: MX2+ 6: MX1+ 7: MX3+ 8: MX2-

Power	Type: Lumberg RSMEESD / 3 pin
	1: Power VCC+ 3: GND 4: not used
	Power cable wires color: 1 = brown 3 = blue 4 = black

Trigger Flash	Type: Lumberg RSMEESD 4pin.
	*) resistor must be used, $I_{OUT} = 16 \text{ mA}$ by $U_{EXT} = 24 \text{ VDC}$ recommended, drawing shown above example for using high active signal
	Trigger / Flash cable wires color *): 1 = brown 2 = white 3 = blue 4 = black

\*) shielded trigger / flash cable should be used and ordered separately

5.2 Flash sync sample  $U_{EXT} = 24\text{ VDC}$  high active:

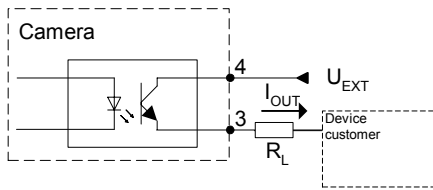

Timing example:  
 measurement condition  $U_{EXT} = 24\text{ VDC} / I_{OUT} = 16\text{ mA}$   
 $R_L = 1.5\text{ kOhm}$

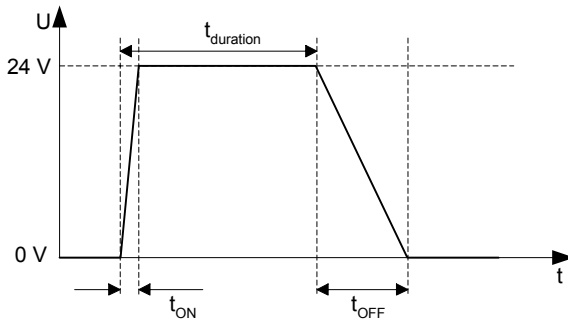

$t_{ON}$  time = typ.  $2\ \mu\text{sec}$   
 $t_{OFF}$  time = typ.  $40\ \mu\text{sec}$

5.3 Flash sync sample  $U_{EXT} = 24\text{ VDC}$  low active:

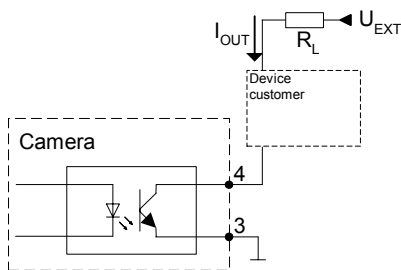

Timing example:  
 measurement condition  $U_{EXT} = 24\text{ VDC} / I_{OUT} = 16\text{ mA}$   
 $R_L = 1.5\text{ kOhm}$

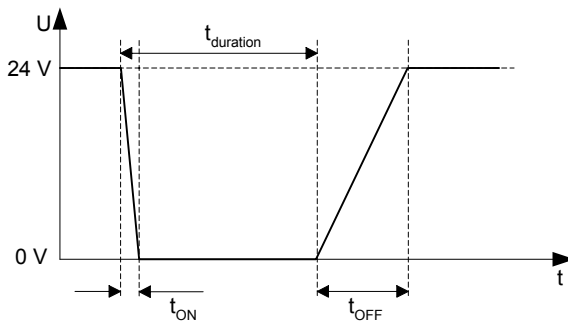

$t_{ON}$  time = typ.  $2\ \mu\text{sec}$   
 $t_{OFF}$  time = typ.  $40\ \mu\text{sec}$